



AUTOMATIC BARRIER

USER'S MANUAL

MODEL: TURBO 4S

OUTLINE

1. Important safety information	3
2. Introduction	3
3. Main technical parameters	3
4. Installation	4
5. Electrical	8
6. Maintenance	10
7. Troubleshooting.....	10
8. Packing list.....	10

1. Important safety information

Carefully read and follow all safety precaution and warnings before attempting to install and use barrier gate. Incorrect installation can lead to severe injury.

- The automatic boom gate should be installed by a qualified technician; otherwise, serious personal injury or property damage may occur.
- Children should not be allowed to play near or operate automatic boom gate.
- Before any job on the boom gate, cut out electrical power.
- Do not in any way modify the components of the automatic boom gate, otherwise serious personal injury or property damage may occur. We do not accept responsibility for damage or injury resulting from installing this boom gate.
- Notify the users that the boom gate is never to be operated unless it is in full view.
- Always keep people and objects away from the boom gate when it is operated.
- Keep remote controls away from children, to prevent the boom gate from being activated involuntarily.
- The distance between the end of the bar and the nearest objects should exceed 0.5m.
- Any changing of the bar by customer is not allowed. If you have any special requirements about the bar, please kindly contact a dealer.
- Under no condition should boom gate be used with bar or spring not attached.
- For your safety, withdraw the crank before switching the power back on.
- For service, call an experienced technician.
- Our company reserves the right to change the design and specification without prior notification.

2. Introduction

- Please read the instructions carefully before proceeding. The automatic boom gate intended for use in parking area, commercial premises or apartment block access.
- Compact design, attractive appearance, safe and reliable performance.
- Soft start & soft stop.
- Self-locking at any position.
- A unique internal spring counterbalance mechanism aids the action of the boom gate.
- Manual operation in case of power failure.
- With RS485 serial communication interface.
- Terminals available to photocell, loop detector and alarm lamp.

3. Main technical parameters

Table 1

Power supply	AC 220x(1 ± 10%)V, 50Hz
Motor power	250W
Duty cycle	80%
Bar length	See table 2
Noise	≤62dB
Measurement	280mm (L) x 270mm (W) x 945mm (H)
Remote control range	≥30m
Environmental temperature	-20° C~+50° C

Table 2

Model	Bar length	Opening time
TURBO 4S	3m-4m(standard)	2s

4. Installation

Necessary Tools

The following tools may be necessary to install the automatic boom gate. You will need standard screwdrivers, an electric drill and spanners.

The entire configuration and dimension are shown in the diagram below.

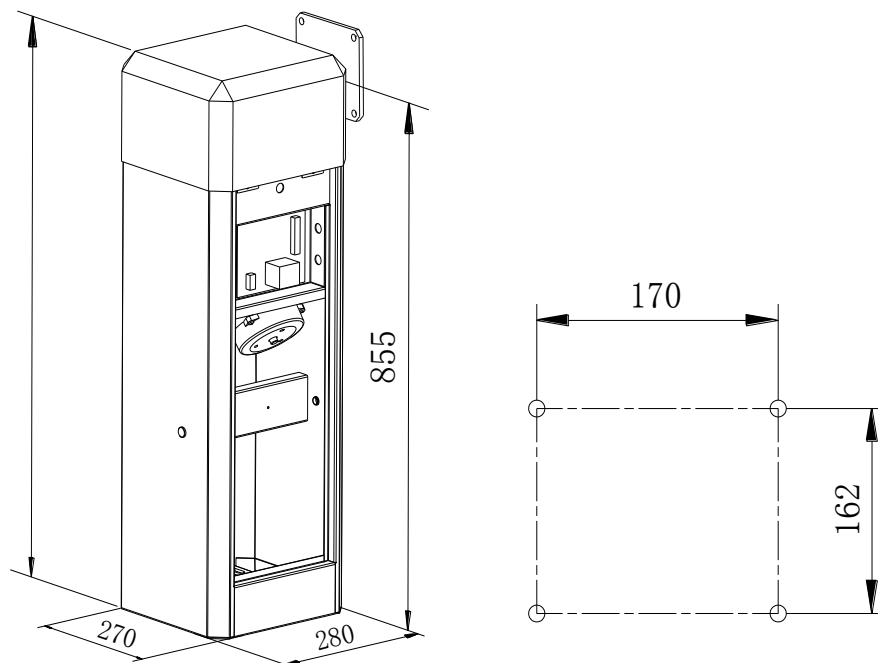

Fig.1

Right-hand boom gate and left-hand boom gate

Our company is normally delivered right hand, if you need to change it to the left proceed as follows:

Loose the M12 bolt, install the flat key and bar base on the left, tight the bolt.

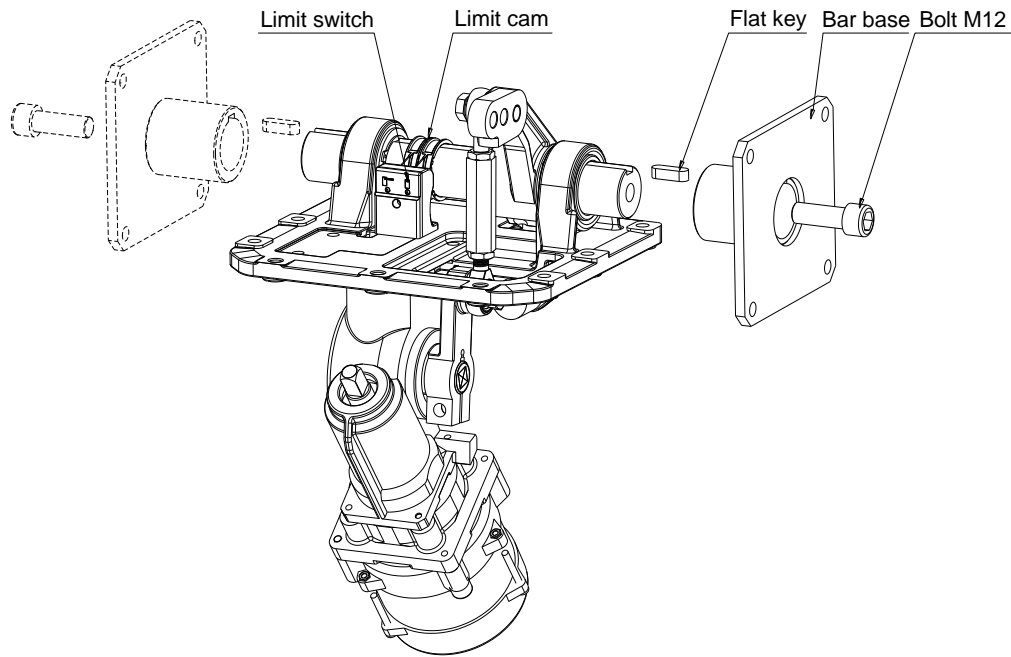

Fig.2

Conduit

Make one input hole for electric wires. In order to protect the wires, conduits must be set into the concrete when it is poured. Wires within the conduit shall be located or protected so that no damage can result from contact with any rough or sharp part.

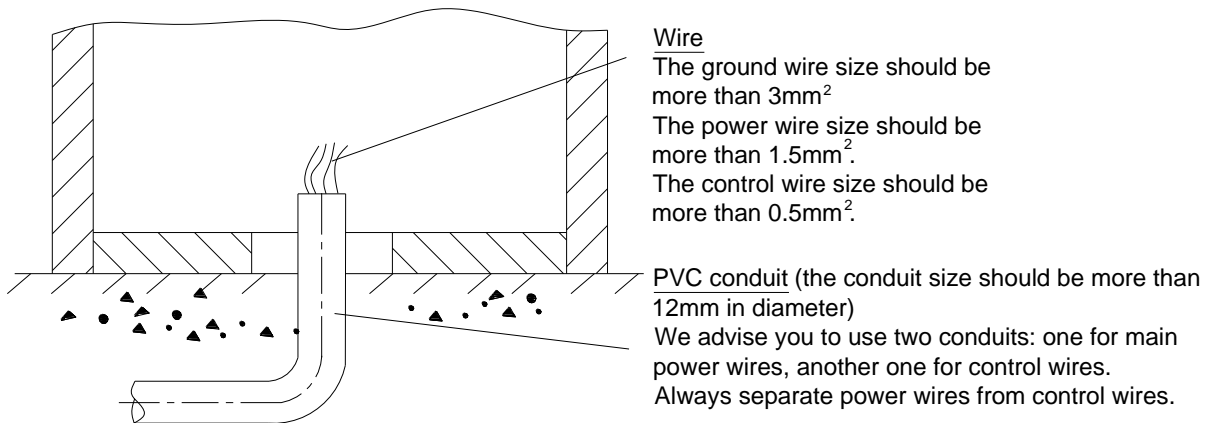

Fig.3

Expansion bolt (see Fig.4)

- The boom gate requires a concrete pad in order to maintain proper stability. Place the boom gate on its concrete pad and check the boom gate orientation with regard to the roadway.
- Mark the base hole locations onto the cement with a pencil or similar.
- Then move the operator to the side and drill the 4 holes on the marks that you have just drawn on the concrete pad.
- Insert the (4) M12 wedge expansion bolts that are provided with the boom gate into the holes or

you can use the (4) M12 bolts, these bolts must be set into the concrete when it is poured.

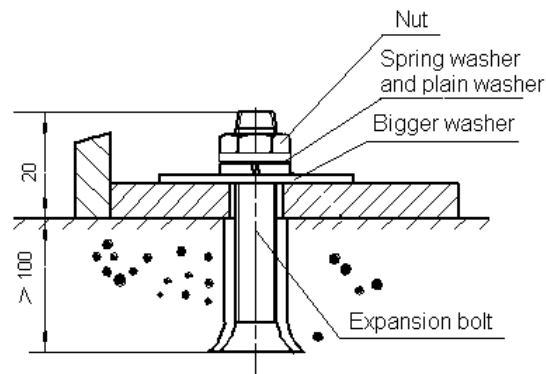

Fig.4

Boom gate

Place the boom gate back into position, mount the boom gate to the concrete pad with washers and nuts.

Bar

Mount the bar to the assembled cubicle and lock it with the four M10×16 socket head screws.

Balancing spring

Correct balancing is essential if boom gate is going to work properly.

Two holes on the driven lever. The boom gate is normally delivered in the first hole. If you need to change it to the second hole proceed as follows:

- Rectify spring force only when the bar is in open position (i.e. the balancing spring is loose).
- Loose the two screws.
- Undo the nut, release the balancing spring by turning the spring adjusting rod clockwise.
- Connect the spring adapter to the second hole of driven lever, tighten the screw.
- Connect the spring adjusting rod to the balancing spring and spring adapter by turning spring adjusting rod anti-clockwise. Tighten the spring adjusting rod to make the balancing spring for ideal condition of use.
- Fasten the nut.

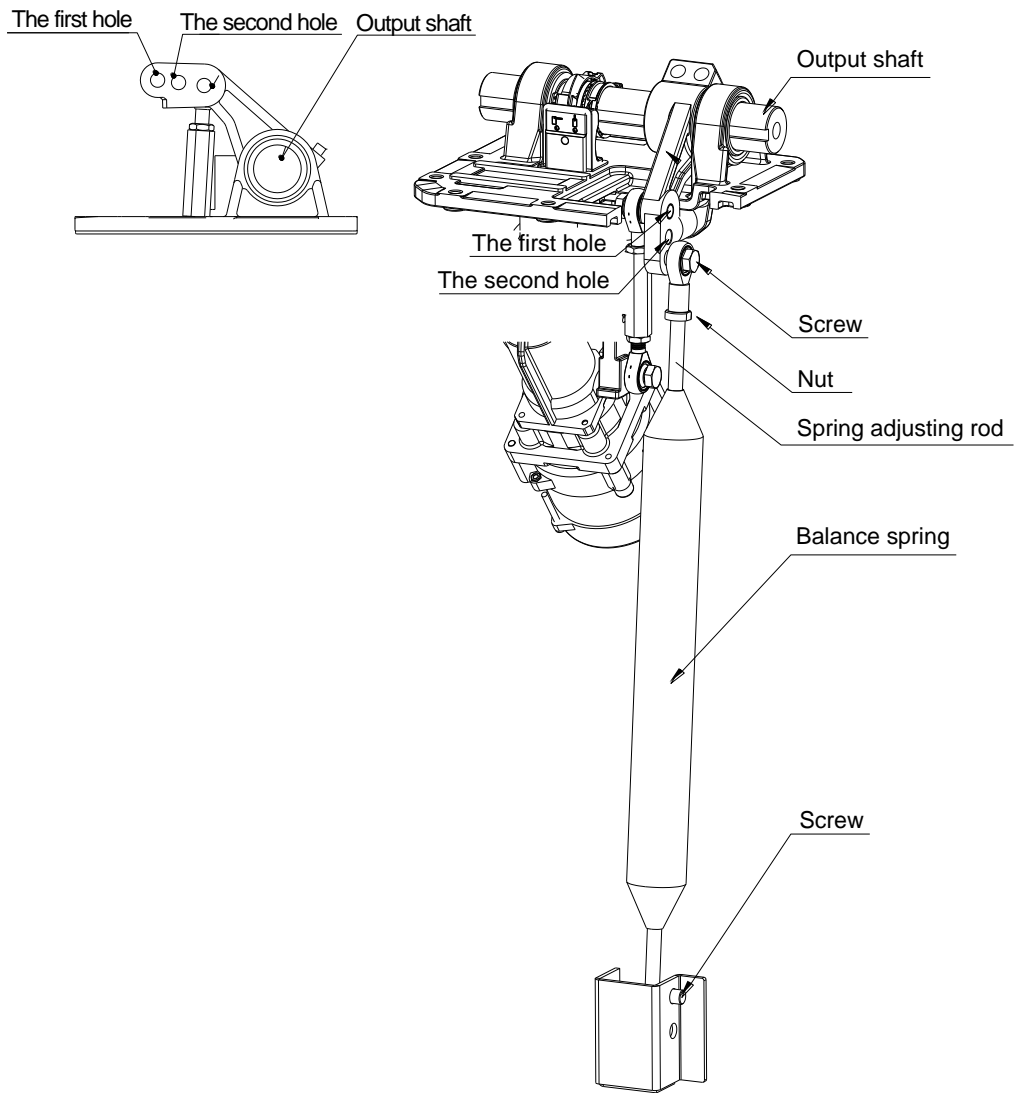

Fig.5

Bar length

Table 3

Model	Bar length	
TURBO 4S	3m-4m	The first hole is for 4m bar. The second hole is for 3m bar.

Manual operation

In case of power failure use crank to open or close boom gate manually, use the crank as follow:

- Shut off the main power of the boom gate. This safety measure is mandatory to avoid any risk of injury in case of accidental running of the motor.

- Insert the crank in the opening of the housing (protected by a cover).
- Turn the crank clockwise or counterclockwise.
- Withdraw the crank before switching the power back on.

Limit switch (normally open contact) see Fig.6

- The adjustable limit switches are used to stop the bar in the opened and closed positions.
- Loose the M4 screw of open limit cam, turn the open limit cam until the open limit switch clicks, then tighten the screws.
- Loose the M4 screw of close limit cam, turn the close limit cam until the close limit switch clicks, then tighten the screws.
- After adjusting, you can open the bar then close the bar and observe whether the bar has successfully reached the opened (vertical) position and closed (horizontal) position. If the bar does not reach the opened position and closed position, you can repeat the adjusting process.

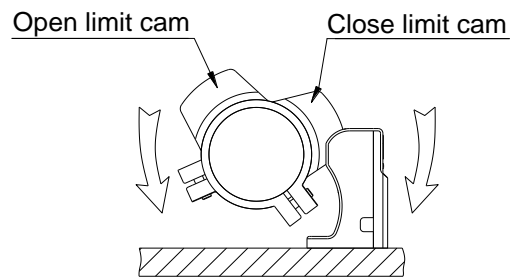

Fig.6

5. Electrical

Remote control

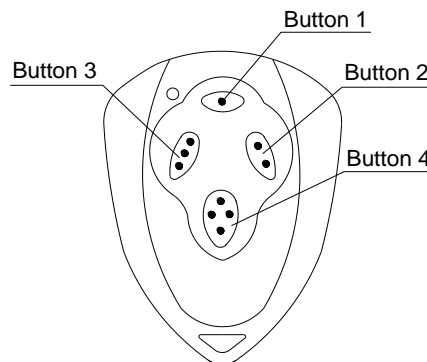

Fig.7

- **To add extra remote controls (Learning):** Press the button 'AN' (see Fig.8) on the control board, the LED2 turns on, then press the remote control button which you want to use, the LED2 turns off, press the same remote control button again, the LED2 flash and then stop. the learning process is finished.
Up to 25 remote controls may be used.
- **Erase remote controls:** To erase all existing remote controls, press and hold 'AN' button till the LED2 indicator light turns off. This indicates that all the remote controls have been erased completely.

- The remote control works in three channel mode. Button 1-open, button 2-stop, button 3-close.
- Verify open direction: If the boom gate does not work in the desired direction, then you will need to reverse the motor operating direction, you can do this by exchanging wires 'V' and 'W'.

Loop detector (N.O.)

- If loop detector detects vehicles during the bar closing, the bar will reopen immediately and stay open until the vehicles move out of the loop, after vehicles move out of the loop, the bar will continue to close.
- If loop detector detects vehicles when the bar stops at vertical or middle position, the bar will remain stop until vehicles move out of the loop. After vehicles move out of the loop, the bar will close.

If loop detector detects vehicles when the bar stops at horizontal position, the bar will not move.

- The bar will keep opening if loop detector detects vehicles during opening. After vehicles pass through the loop, the bar will close.

Move the jump cap on ON, the bar will close after 2 seconds after vehicles move out of the loop.

Move the jump cap in OFF position, the bar will close immediately after vehicles move out of the loop.

Infrared photocell (N.O.)

If infrared beam is interrupted during closing, the bar will reopen immediately.

Limit switch (N.O.)

- The switch is used to accurately stop the bar in the vertical and horizontal positions.
- If the bar stops at opened position (vertical) when the limit switch is reached, the bar will not move if you press open button of button switch.
- If the bar stops at closed position (horizontal) when the limit switch is reached, the bar will not move if you press close button of button switch.

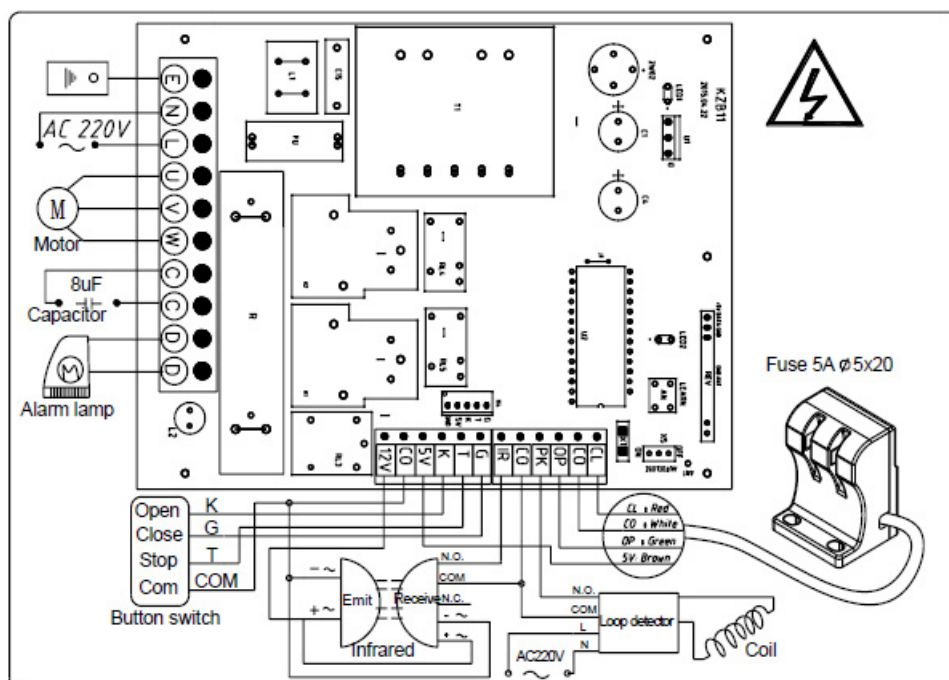

6. Maintenance

- Every 6 months regularly grease the wheels and axles.
- Check if all screws and nuts have been tightened firmly.
- Check if all wires are firmly connected to their respective terminal blocks.
- Make sure the bar is correctly fixed.
- Check the general state of the balancing spring.
- Keep boom gate clean at all times.

7. Troubleshooting

Table 4





No.	Trouble	Possible causes	Solutions
1	The bar fails to close or open fully.	Limit switch	Re-adjust the limit switch.
2	The bar opens too slowly.	Balancing spring	Adjust the balancing spring rod or replace the balancing spring.
3	LED1 on the control board does not light.	Fuse blown	Replace fuse
4	The remote control operating distance is too short or not far enough.	Battery level may be low.	Replace the battery inside of the transmitter or try another transmitter.
5	The indicator light of the transmitter does not light.	Poor contacted.	Replace the transmitter.

8. Packing list

Make sure that all parts are included before using. Refer to packing list. If any parts appear to be missing, contact a dealer.

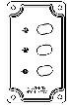
Table 5

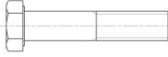
No.	Item	Quantity
1	Assembled cubicle	1
2	Bar locking bracket	1
3	Crank	1
4	Transmitter	2

5	Button switch		* optional
6	Expansion bolt		4
7	Washer 12 for mounting bar		2
8	Bolt M12X65 for mounting bar		2
9	Nut M12 for mounting bar		2
10	Bigger washer		4
11	User' manual		1